



April 12th, 2017 12:00 PDT/ 3:00 EDT

HEPATITIS DELTA: THE HIDDEN EPIDEMIC

Epidemiology, natural history, virology and a historical
perspective on treatment

Robert G Gish MD
Professor Consultant,
Stanford University

Medical Director
Hepatitis B Foundation

A decorative footer consisting of two horizontal bars: a maroon bar on the left and a blue bar on the right.

Epidemiology of Hepatitis Delta

Key messages

- An estimated 15-20 Million individuals are infected with HDV worldwide!
- Hepatitis Delta is the most severe form of chronic viral hepatitis
→ No testing – no identification of HDV infection!
- The clinical manifestations of hepatitis delta differs between regions and has changed during the last 3 decades
- Hepatitis Delta is a dynamic disease:
 - Both HBV and HDV contribute to disease progression
- Migrant populations and special risks groups show particular high HDV prevalence
- The HDV genotype matters

After: H Wedemeyer

HDV epidemiology

- HDV = delta-virus, delta-agent
- Always found in association with HBV-infection
- Worldwide infection \approx 15-20 million
- The most common routes of transmission
 - intravenous transmission (IDU)
 - percutaneous transmission (tattoo, piercing)
 - sexually transmission
 - intrafamilial transmission
- Endemic regions
 - Mongolia
 - Mediterranean countries (most often in children and young people)
 - Far East (infectiousness varies from 90% among HBsAg-carriers living in the Pacific Islands, up to 5% HBsAg-carriers in Japan)
 - Amazonia

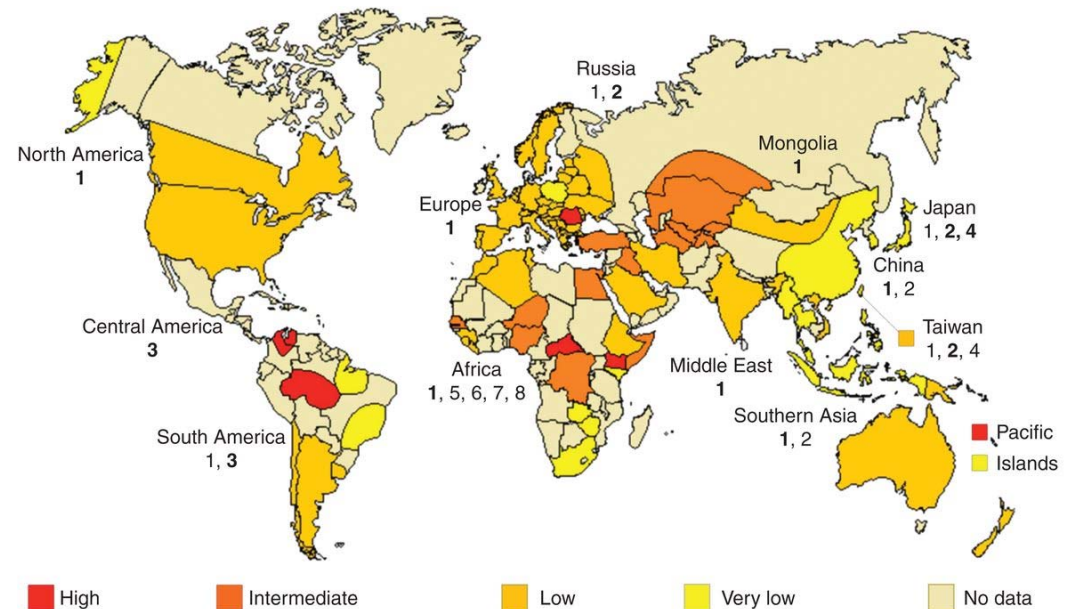

Different HDV genotypes in different regions!

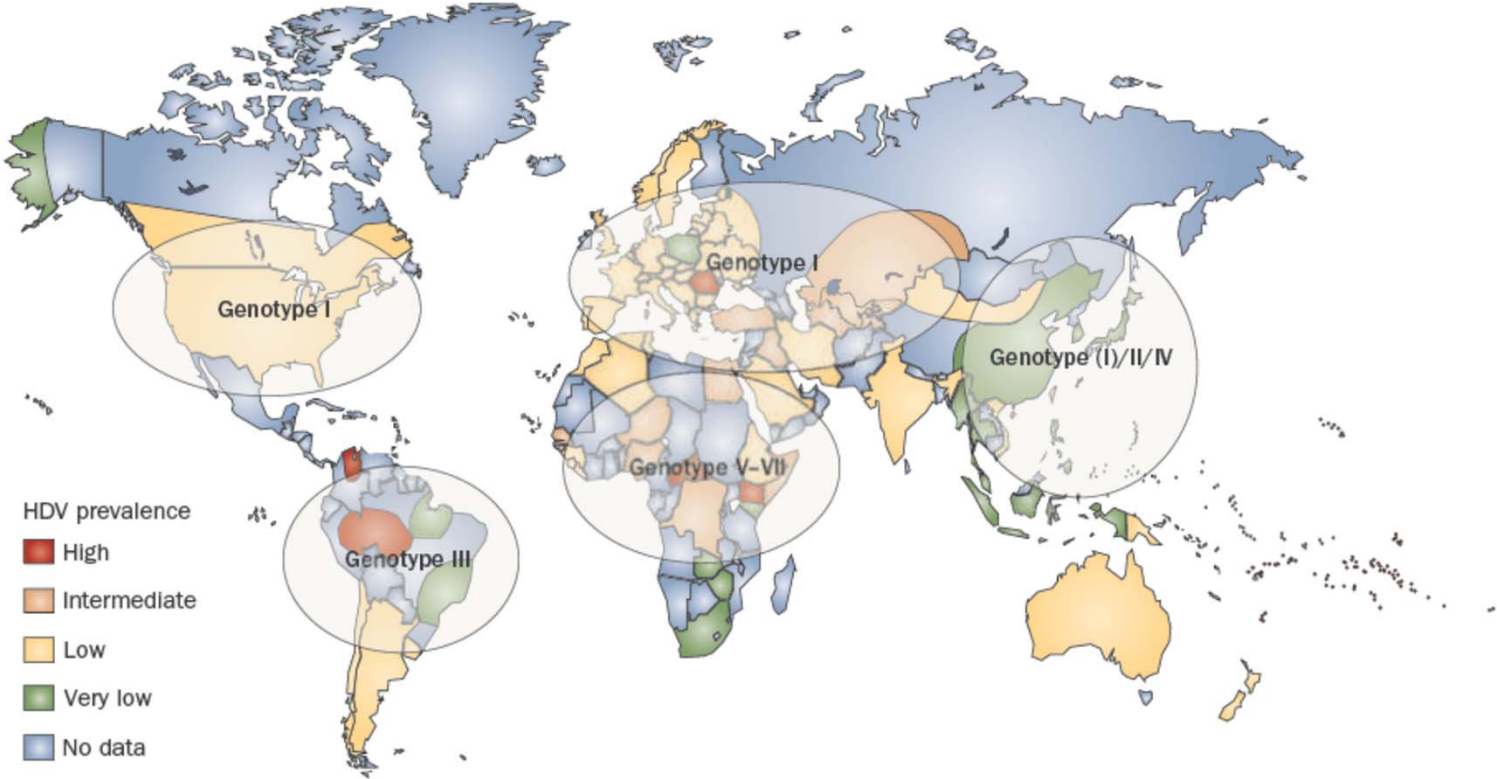

Prevalence of Hepatitis Delta in the Asia-Pacific Region

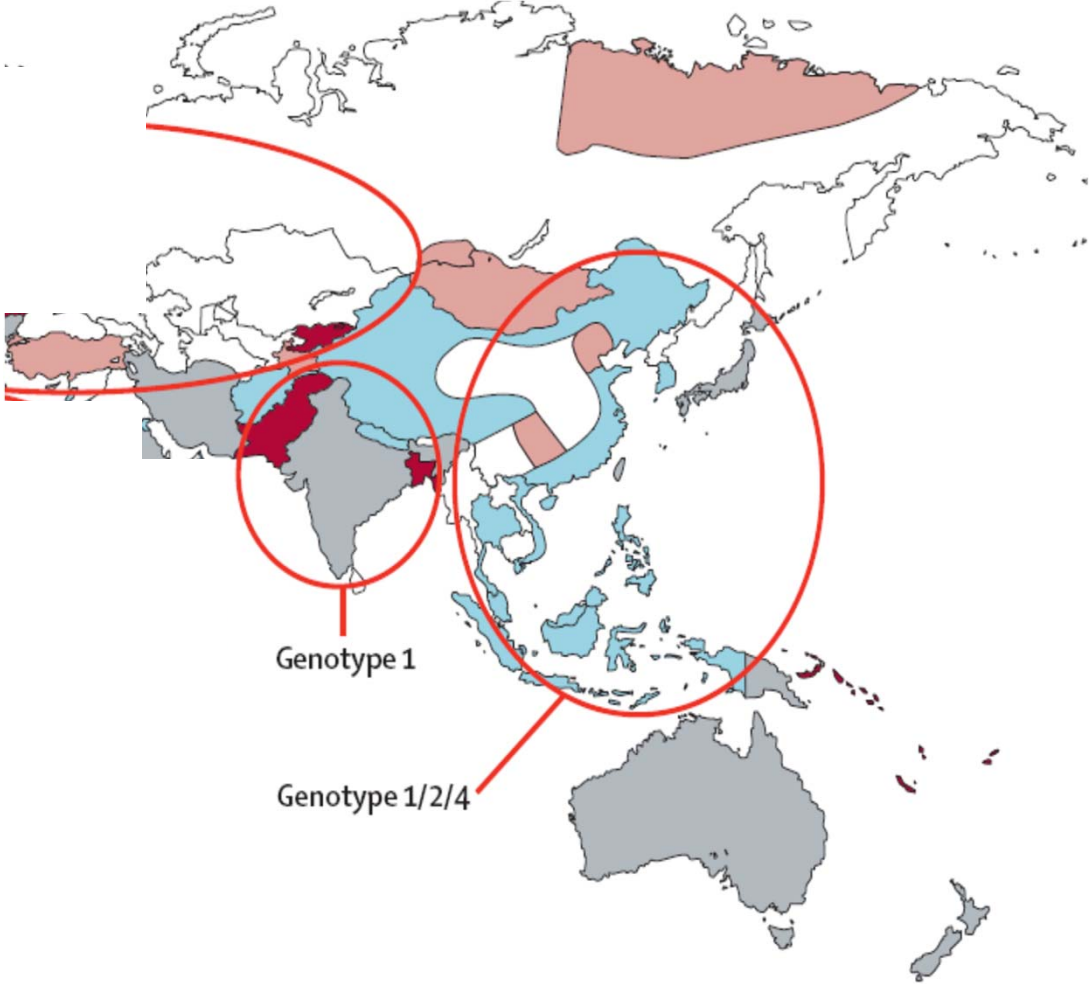

Hughes et al. The Lancet 2011; Abbas et al., World J Gastroenterol 2012

Prevalence of Hepatitis Delta in the Asia-Pacific Region Data presented at the EASL Delta Conference 2010

Country	Prevalence	Author	Poster No
India	15.2%	Raja W.A. et al.	82
	10.9%	Asim M.	8
Korea	0.4% (OLT)	Jung Y. J. et al.	47
Pakistan	35.2%	Mumtaz K. et al.	71
	45.3%	Zaki M. et al.	7
	40.0%	Bhatti T.A. et al.	13
	45.3%	Memon M. S. et al.	95
Iran	7.6%	Azinmehr L. et al.	11
Turkey	2.5% (Izmir)	Köse S. et al	26
	3.4% (Izmir)	Akpınar Z. . et al	40
	8% (SE)	Turhanoglu M. et al.	41
	9% (Ddiyarbakir)	Gulsun S. et al.	58

Prevalence of Hepatitis Delta in Africa

➤ Genotypes 1, 5-8

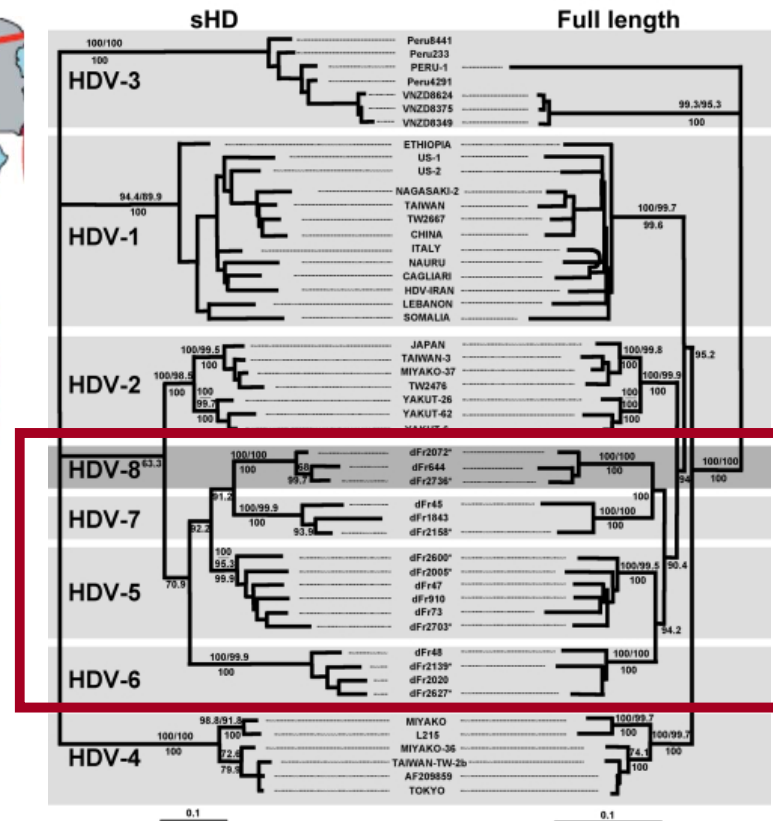
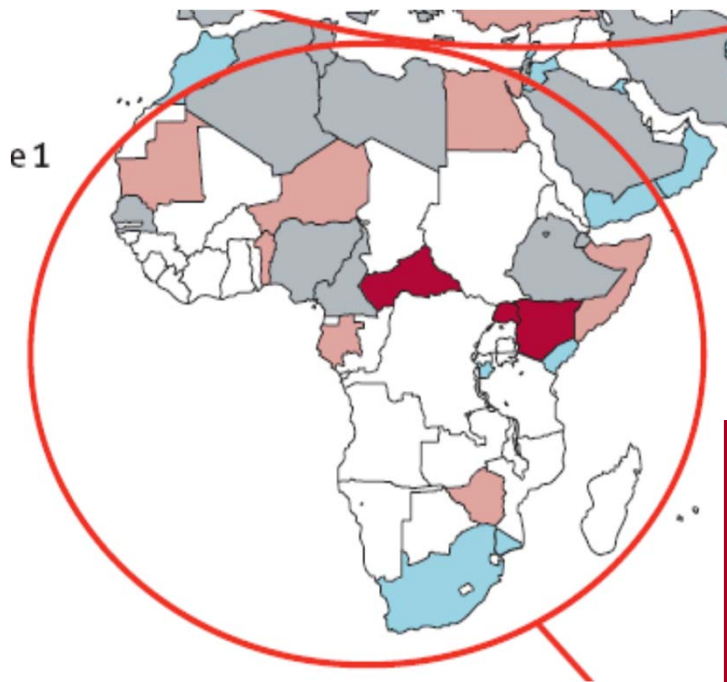

Le Gal et al., Emerg Infect Dis 2006

Anti-HDV Prevalence among HBsAg-positive patients in Europe (E.K. Manesis, EASL Special Conference 2010)



Decline of anti-HDV prevalence in Eastern Europe in the 1990ies

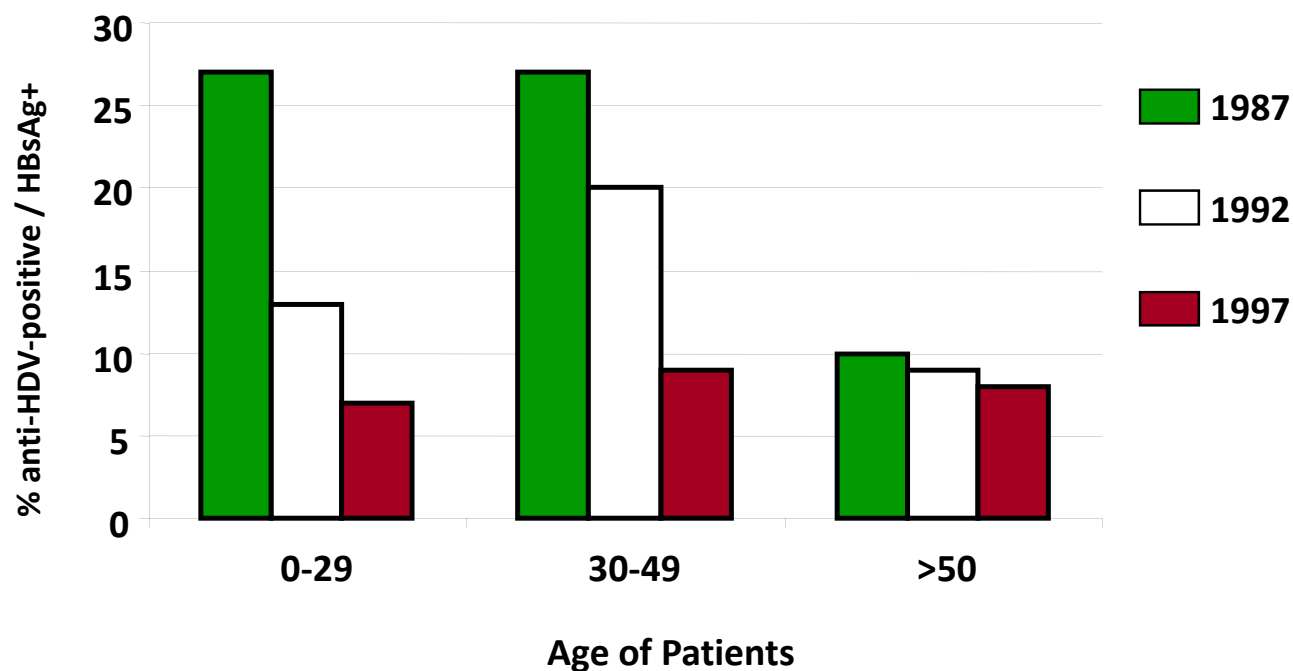

Gaeta, Rizzetto et al., Hepatology 2000

Older Data: HDV Epidemiology in the USA

Highly variable: <1% to 30% among chronic HBV carriers!

Nath et al. Am J Epidemiol 1985:

Blood Donors: 1.4% Southeast to 12% Pacific region

Hershow et al. Ann Intern Med 1989:

Hepatitis B Carriers in Illinois: 30%

Weisfuse et al. Hepatology 1989:

Homosexual Men: 2%

Rizzetto et al. JID 1982; Troisi et al. Blood 1993:

Haemophiliacs: 19%; Female Prostitutes 21%

NHANES IV (CDC: 2003-2004)

1/28 HBsAg+ individuals was anti-HDV+ (3.6%)

From 1999 to 2012, data on 71,916 individuals were obtained, with 52,209 (72.6%) receiving HDV testing. The overall prevalence of HDV in the United States was 0.02% (10/52209), with a mean age of 52.1 ± 14.0 years and 60% males. Table 1 summarizes our results.

TABLE 1. Patient Demographics and Clinical Characteristics Stratified by HDV Status

Variable	HDV-Negative, % (n = 52,199)	HDV-Positive (%) (n = 10)	<i>P</i>
Mean age, years (SD)	36.6 (23.01)	52.1 (14.01)	0.02
Sex			
Male	49.2	60.0	0.54
Female	50.8	40.0	
Race/ethnicity			
Mexican American	23.3	10.0	0.01
Other Hispanic	7.1	0	
Non-Hispanic white	40.3	10.0	
Non-Hispanic black	23.3	50.0	
Other race, including multiracial	6.0	30.0	
HCV antibody			
Positive	1.2	20	0.08
Negative	98.8	80	
HIV status			
Positive	0.5	20	0.03
Negative	99.5	80	
Injection drug use			
Yes	2.8	0	0.99
No	97.2	100	
Homosexual men			
Yes	5.2	25	0.19
No	94.8	75	

Fisher's exact test was used for categorical variables and the Mann-Whitney test for continuous variables.

Abbreviations: HCV, hepatitis C virus; HIV, human immunodeficiency virus; SD, standard deviation.

HDV infections in the US population

- **Recent indications that HDV prevalence is increasing**
- **HDV prevalence in US was not assessed widely:**
- Baltimore (n=194/258): prevalence declined from 15% to 11% in IVD between 1988-1989 and 2005-2006²
 -
- US Veterans (n=2175 HBsAg + and tested for HDV): 3.4% positive³
- NHANES 1999-2012 weighted data: 0.02% prevalence⁴
- Need for improved surveillance in the US

HDV Epidemiology in the USA: Northern California

1296 HBsAg positive patients (incomplete data) → **82 (6.3%)** anti-HDV positive

499 HBsAg positive patients (complete data) → **42 (8.4%)** anti-HDV positive

- 71% male
- 54% non-hispanic Caucasians
- 28% asian-pac. immigrants
- 34% anti-HCV positive (with 67% cirrhosis)

HDV in the US VA

- 3.5% of HBsAg+ who were tested were anti-HDV positive
- Predictors of being HDV tested included
 - male gender (4.5 vs. 1.3%, $p < 0.001$)
 - Asian ethnicity (8.5 vs. $\leq 5\%$ any other*, $p < 0.001$)
 - HBcIgM+ status (29 vs. 9.0% of HBcIgM-*, $p < 0.001$)
 - HBeAg+ (21.3 vs. 13.0% HBeAg-*, $p < 0.001$)
 - HCVAb+ (5.3 vs. 4.3% HCVAb-*, $p < 0.001$)
 - HIV+ (9.4 vs. 4.0% HIV-*, $p < 0.001$)
 - ALT (peak ± 180 d, 383 vs. 95u/l, $p < 0.001$)
 - HBV DNA > 2000 IU/ml (21.8 vs. 14.7%*, $p < 0.001$)

HDV in the US VA (part 2)

- 74 HDV+ individuals
 - ▣ 43 (58%) were HCVAb+
 - ▣ 7 (9.5%) HIV-coinfected.
- ▣ There was no difference in age, ethnicity, or comorbidity in HDV+ and HDV- subjects
- ▣ 69% of HDV+ were HBeAg-, 74% HBeAb+, and 23/26 (88%) had HBV DNA titers <2000 IU/ml.

HDV Epidemiology in the USA

Prevalence, Correlates, and Viral Dynamics of Hepatitis Delta among Injection Drug Users

Lauren M. Kucirka,² Homayoon Farzadegan,¹ Jordan J. Feld,⁵ Shruti H. Mehta,¹ Mark Winters,⁴ Jeffrey S. Glenn,⁴ Gregory D. Kirk,¹ Dorry L. Segev,^{1,2} Kenrad E. Nelson,¹ Morgan Marks,¹ Theo Heller,³ and Elizabeth T. Golub¹

	Patients positive for HDAb				<i>P</i> value
	1988–1989		2005–2006		
HBV serology	Proportion of patients	Percentage of patients (Wald 95% CI)	Proportion of patients	Percentage of patients (Wald 95% CI)	
HBsAg positive	14/48	29 (16–42)	19/38	50 (34–66)	.048
HBsAg positive, adjusted				55 (40–71) ^a	.01 ^b
HBsAg negative	16/146	11 (6–16)	6/220	3 (1–5)	.002
HBcAb and sAb positive	6/57	11 (3–19)	1/108	1 (0–2)	.003
HBcAb positive only	10/89	11 (4–18)	5/112	4 (1–8)	.07
All HBV categories	30/194	15 (10–21)	25/258	10 (6–24)	.2

Kurcirka et al., JID 2010

Participation in the 1st International Quality Control for HDV RNA Quantitation (2013)

Figure 2

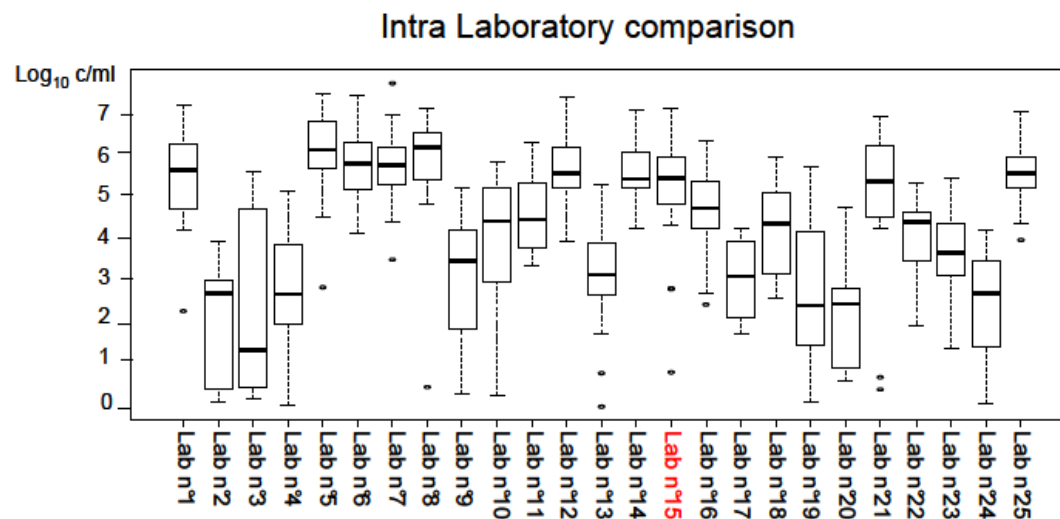

Newly Diagnosed HDV Patients in the US (Unique Patients)

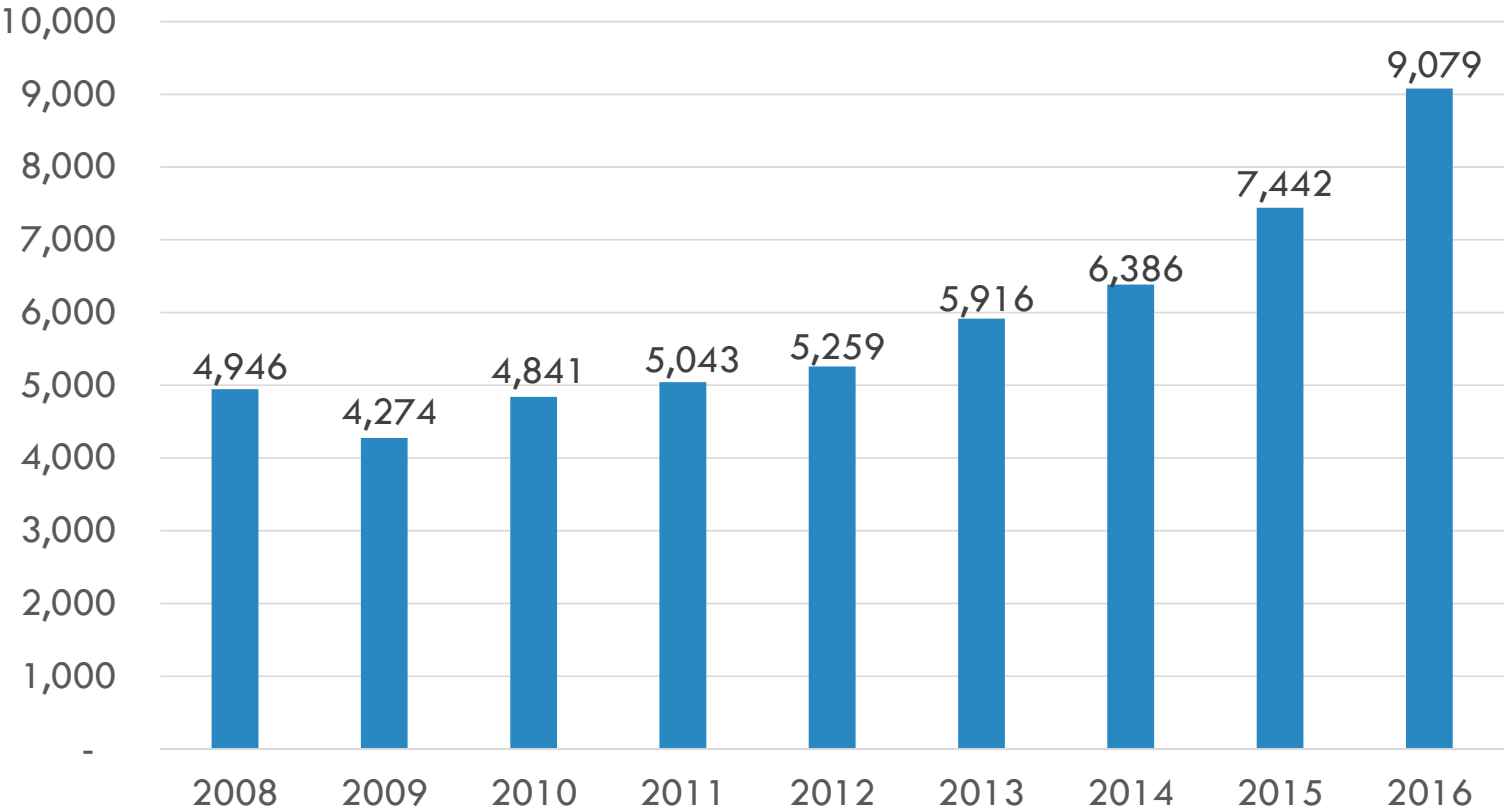

Source: Martins, E and Glenn, J. Prevalence of Hepatitis Delta Virus (HDV) Infection in the United States: Results from an ICD-10 Review. Poster Sa1486 DDW May 2017.

Chronic HBV Pts and % Pts with HDV

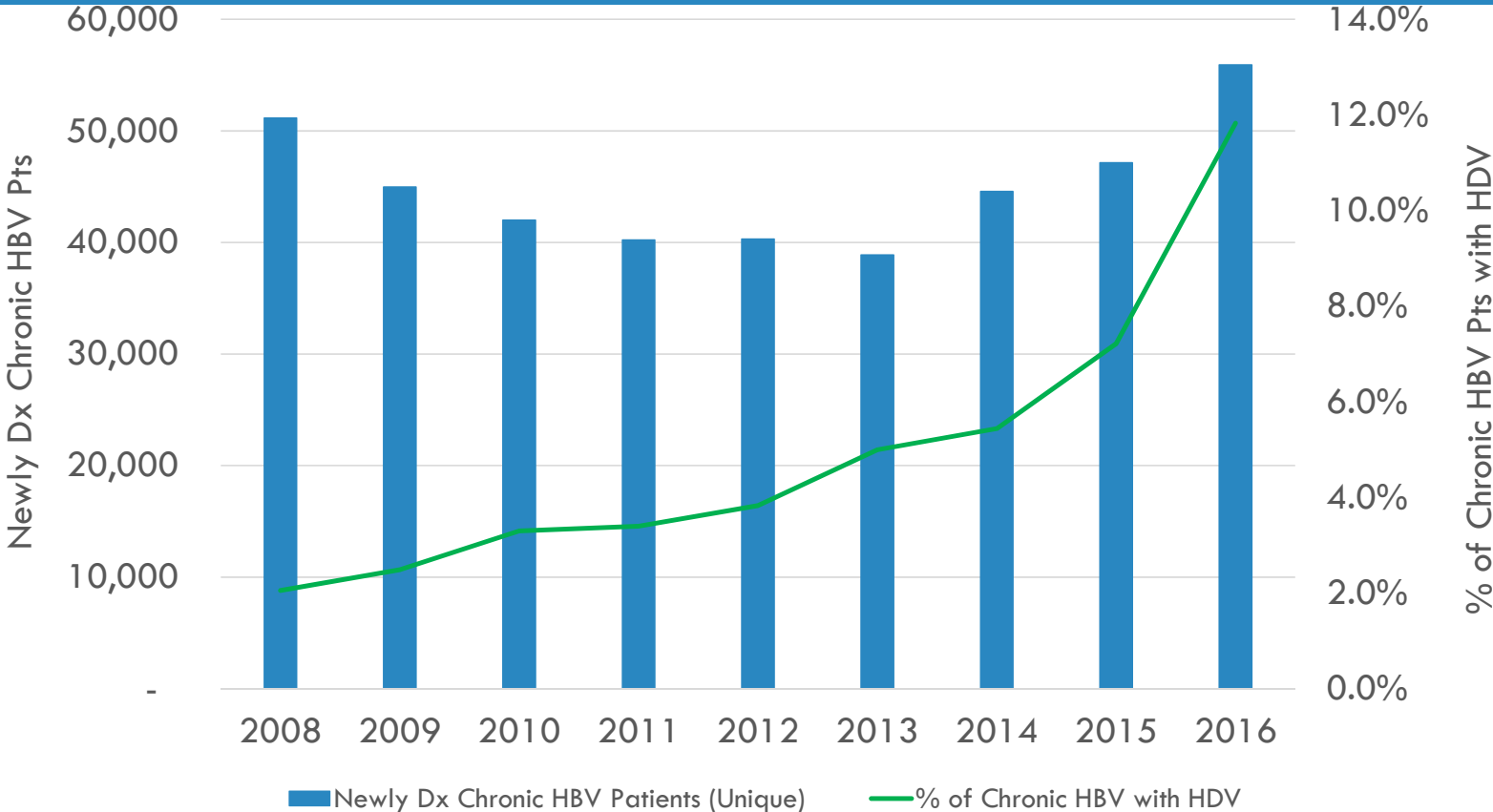

Source: Martins, E and Glenn, J. Prevalence of Hepatitis Delta Virus (HDV) Infection in the United States: Results from an ICD-10 Review. Poster Sa1486 DDW May 2017.

HDV Tests Ordered and % Chronic HBV Patients Tested for HDV

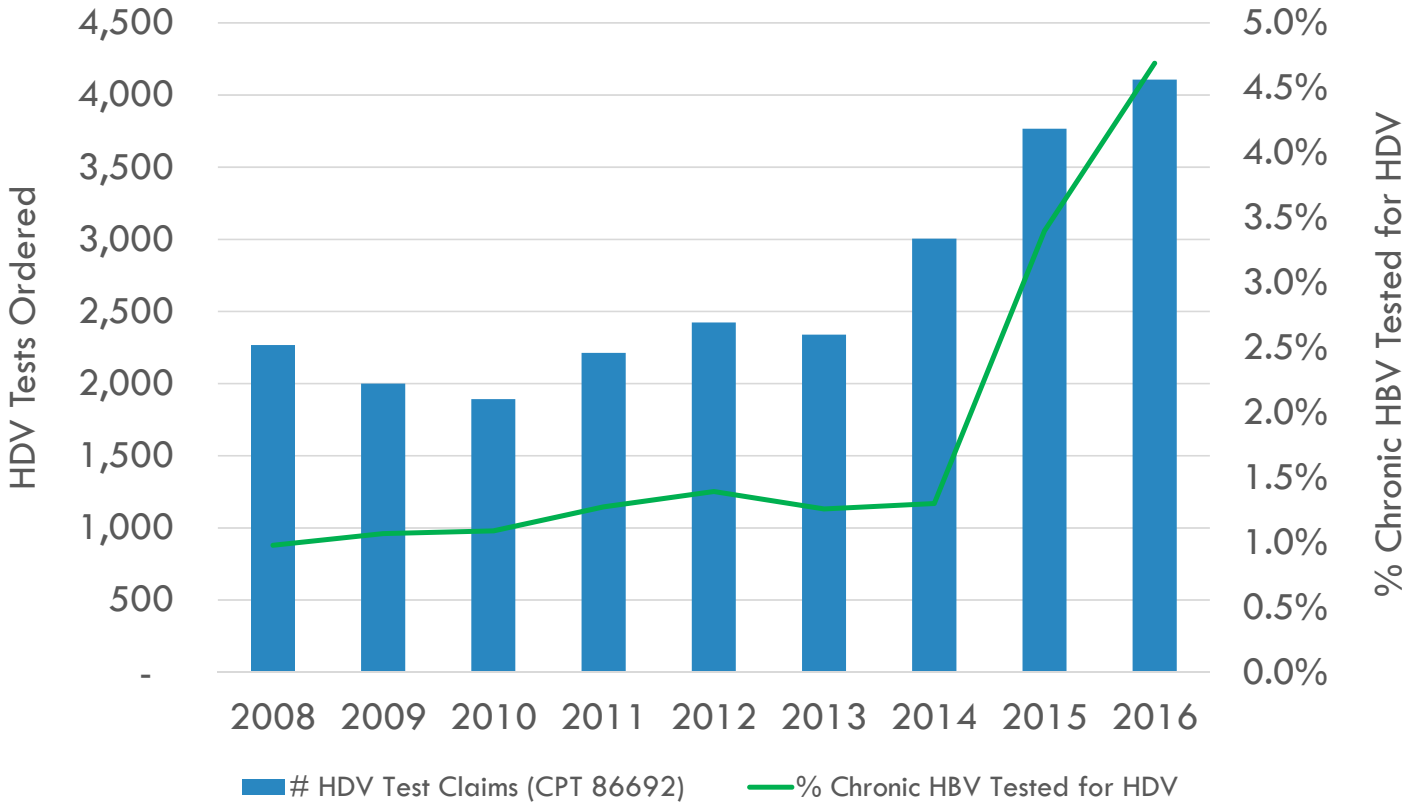

Source: Martins, E and Glenn, J. Prevalence of Hepatitis Delta Virus (HDV) Infection in the United States: Results from an ICD-10 Review. Poster Sa1486 DDW May 2017.

Top 20 US Geographies for HDV Patients

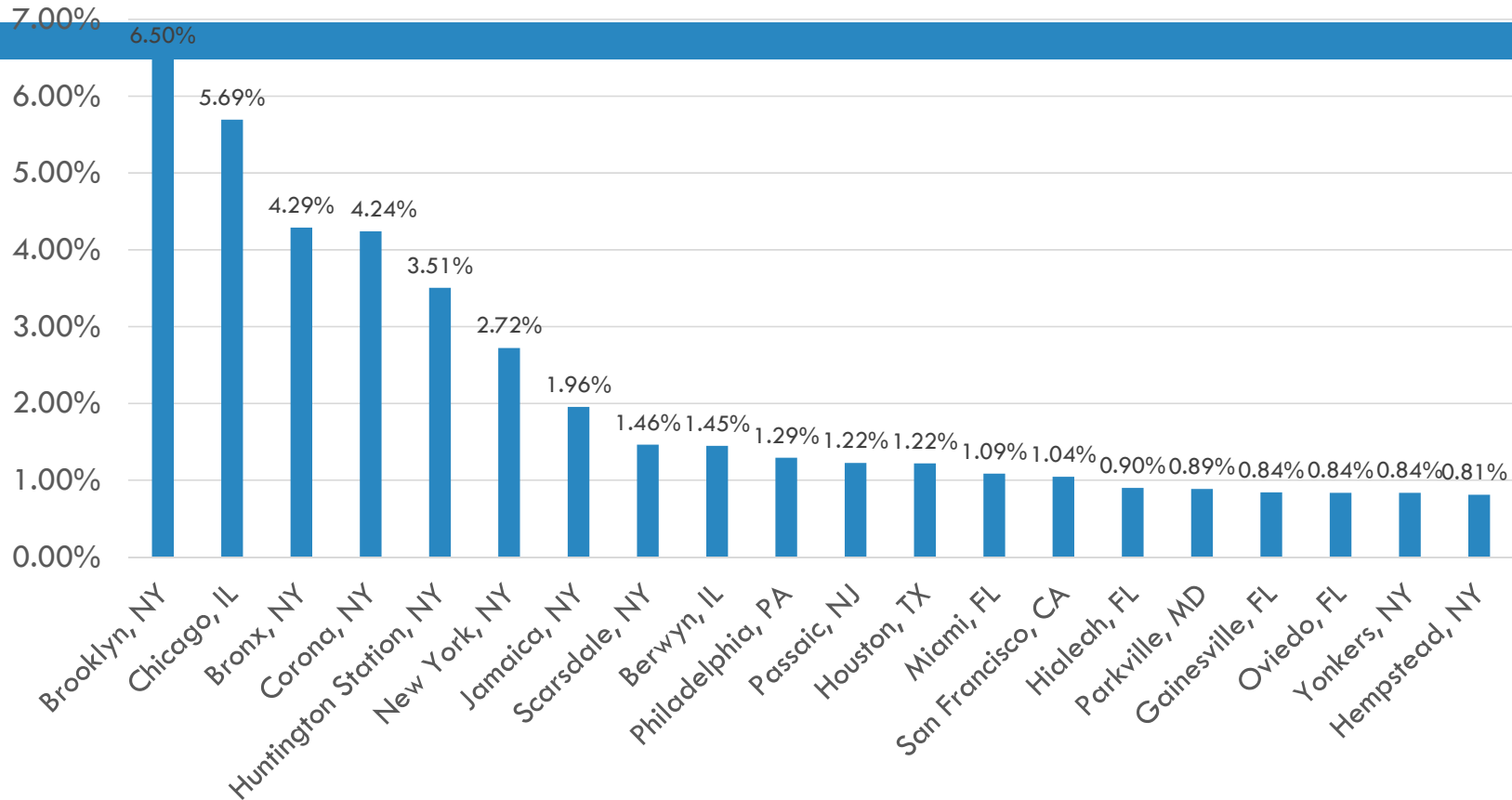

Source: Martins, E and Glenn, J. Prevalence of Hepatitis Delta Virus (HDV) Infection in the United States: Results from an ICD-10 Review. Poster Sa1486 DDW May 2017.

Comparison of HDV Patient Footprint 2008 vs 2016 and Top 20 Geographies for Each Year

2008

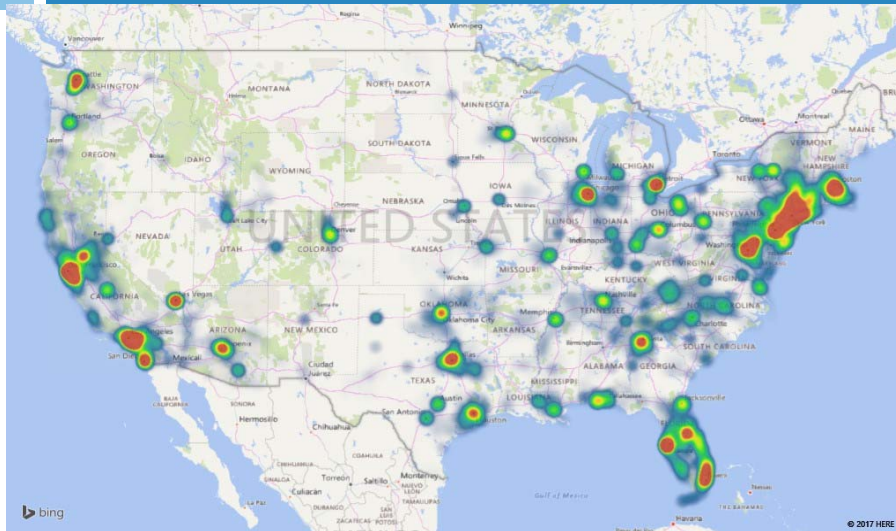

1. Brooklyn, NY	6. Bronx, NY	11. La Puente, CA	16. Chicago, IL
2. New York, NY	7. Philadelphia, PA	12. St. Petersburg, FL	17. Franklin, MA
3. Yonkers, NY	8. Jamaica, NY	13. Staten Island, NY	18. Las Vegas, NV
4. Corona, NY	9. San Francisco, CA	14. Pittsburg, CA	19. Newburgh, NY
5. Scarsdale, NY	10. Passaic, NJ	15. Detroit, MI	20. Huntington ST, NY

2016

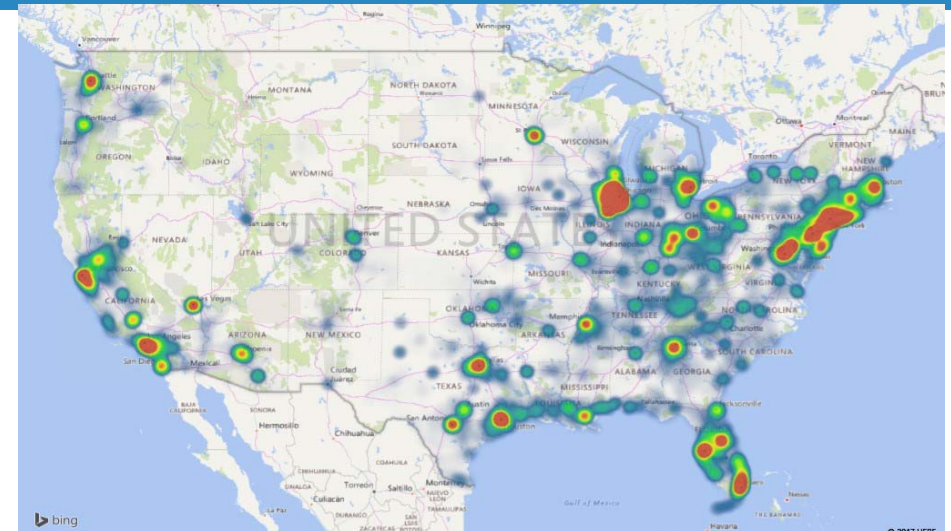

1. Chicago, IL	6. New York, NY	11. Huntington ST, NY	16. Cicero, IL
2. Berwyn, IL	7. Bronx, NY	12. Philadelphia, PA	17. Parkville, MD
3. Brooklyn, NY	8. Jamaica, NY	13. Houston, TX	18. Miami, FL
4. Corona, NY	9. Lombard, NY	14. Passaic, NJ	19. Hialeah, FL
5. Waukegan, IL	10. Aurora, IL	15. Staten Island, NY	20. Las Vegas, NV

Source: Martins, E and Glenn, J. Prevalence of Hepatitis Delta Virus (HDV) Infection in the United States: Results from an ICD-10 Review. Poster Sa1486 DDW May 2017.

HDV in a “low prevalence” country

□ Vietnam

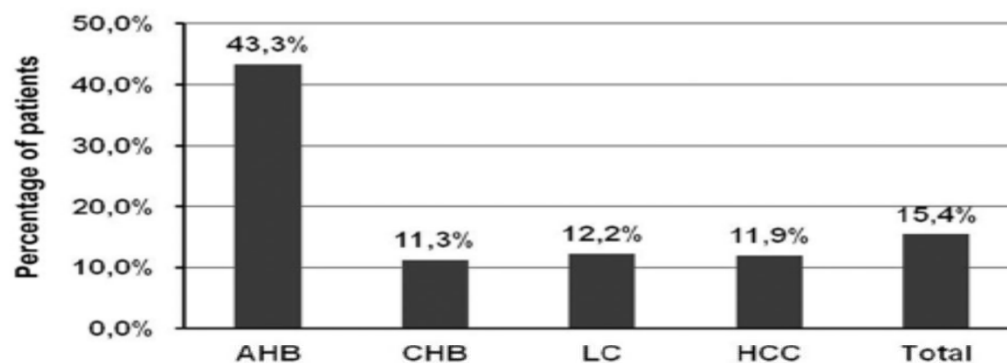
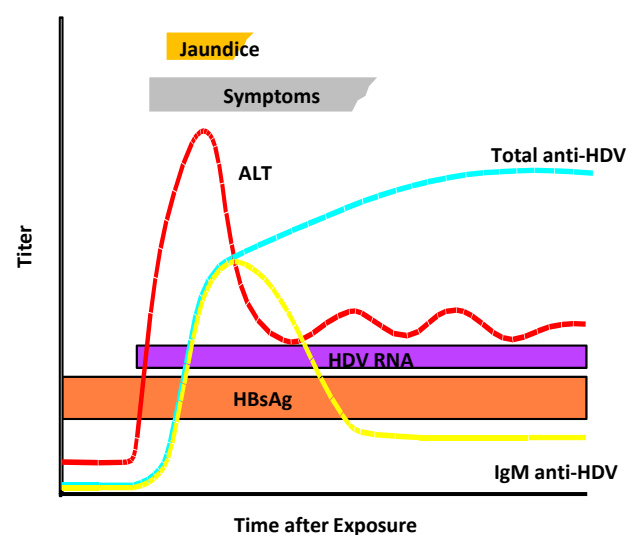
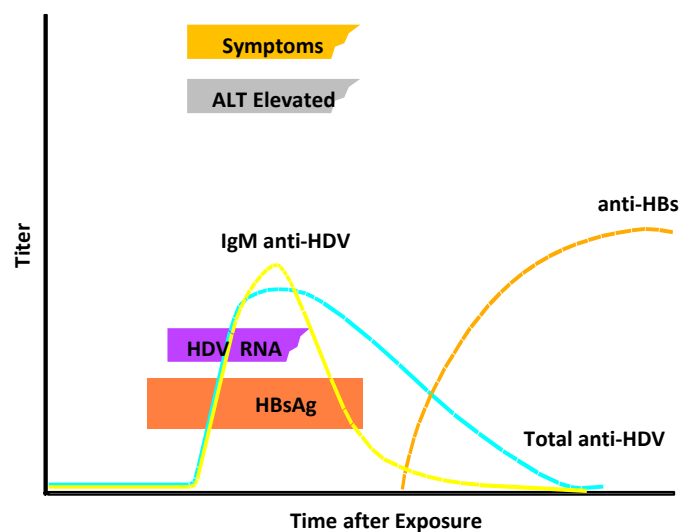

Figure 2. Prevalence of HDV genomes in the HBsAg-positive Vietnamese patients. The prevalence of HDV infection in AHB group was significantly higher in comparison to the CHB, LC and HCC groups (OR =0.19 (CI95 [0.23-0.66]), 0.20 (CI95 [0.08-0.54]), 0.25 (CI95 [0.22-0.71]), respectively; two tailed Fisher’s exact test, $p < 0.01$). Overall, the HDV-prevalence of all patient groups was 15.4% (CI95 [11.1-19.8]) (Total).

doi: 10.1371/journal.pone.0078094.g002

HDV co- and superinfection



- Co-infection:
 - Clinically indistinguishable from acute HBV
- Usually acute and self-limited (95%), HDV and HBV clearance
- High frequency of acute liver failure in IDUs
- Severe hepatitis in previously diagnosed HBsAg-carrier or exacerbation of a known chronic HBV
- HDV becomes chronic almost in 90%

Hepatitis delta: evolution of clinical presentation

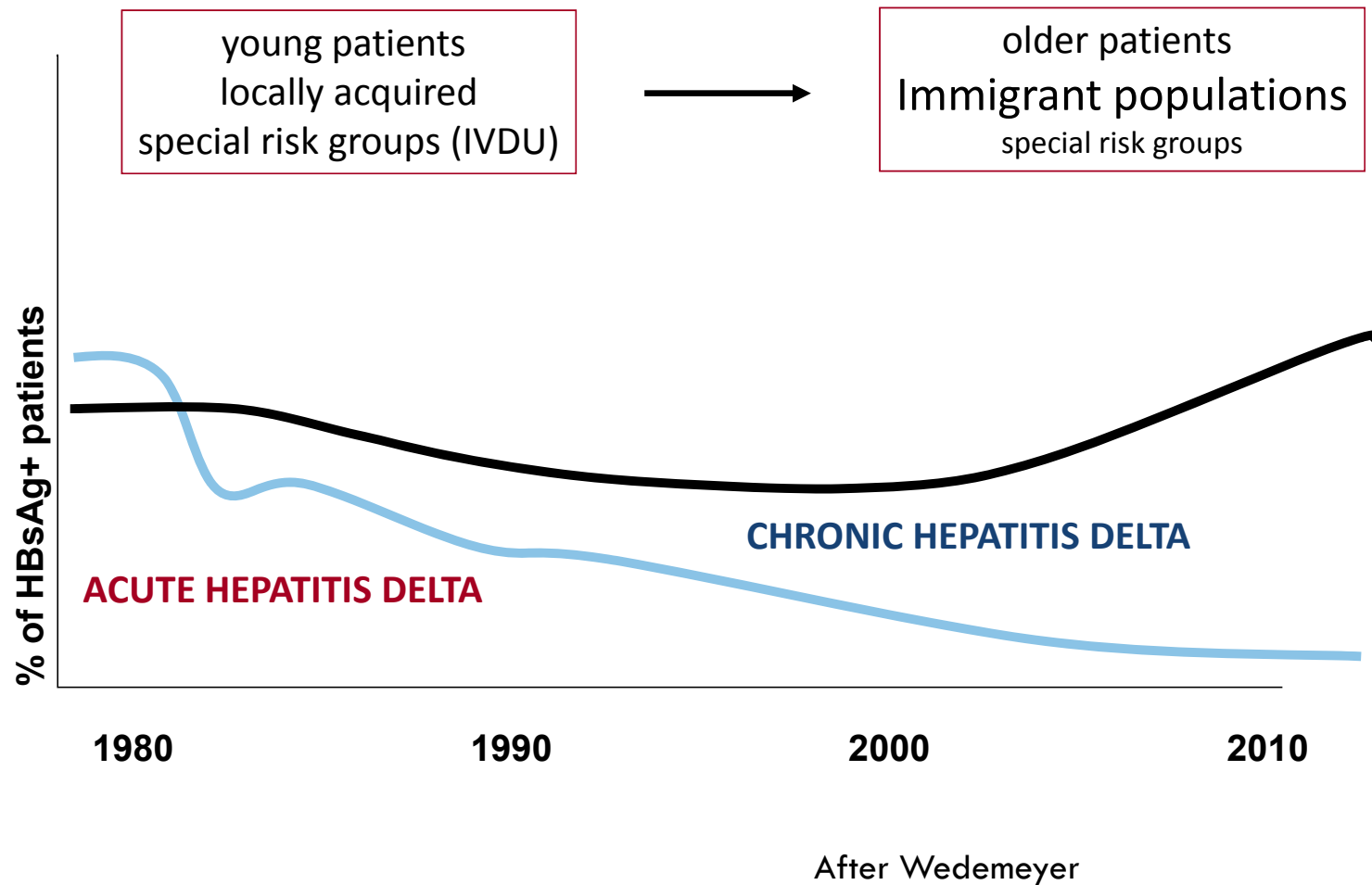

Hepatitis delta: evolution of clinical presentation

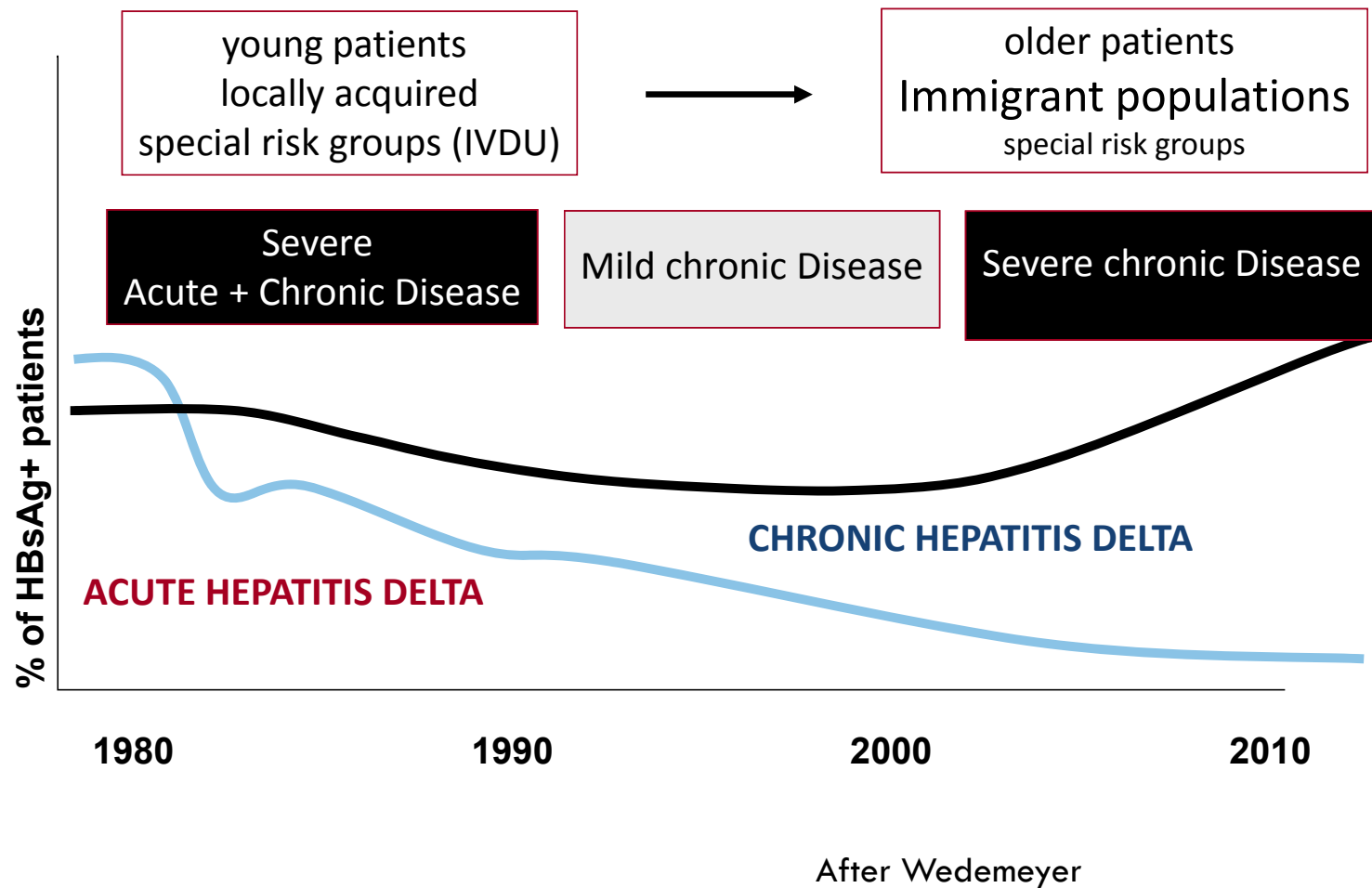

HDV: Virology

➤ HDV Transmission requires HBsAg!

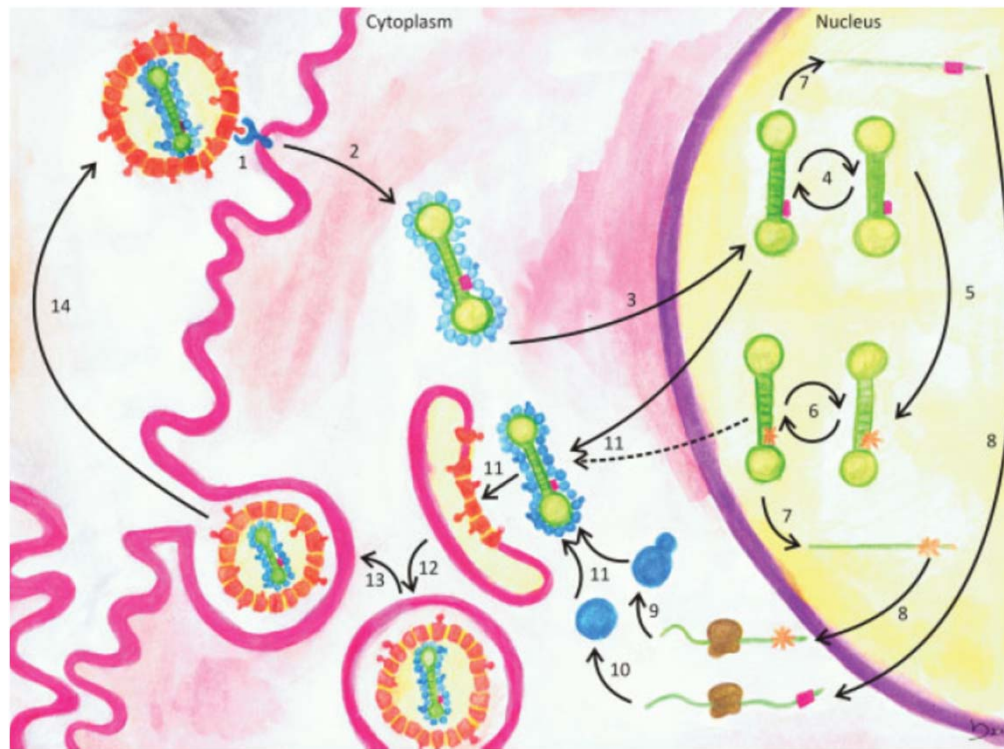

Calle Serrano, Manns & Wedemeyer, Seminars in Liver Disease 2012

HDV: Modes of Transmissions

- HDV Transmission requires HBsAg!
- Intrafamilial transmission
 - vertical & sexual transmission, infection during early childhood*
- *Folk remedies, scarification, percutaneous exposure*
- Medical treatment
 - blood transfusion, unsterile syringes, etc.*
- Special risk groups
 - IV drug user, dialysis, HIV+, hemophiliacs.*
- **HBV vaccination prevents from HDV infection!**

Calle Serrano, Manns & Wedemeyer, Seminars in Liver Disease 2012

HBV DNA is often suppressed by HDV, even in HBeAg-positive hepatitis

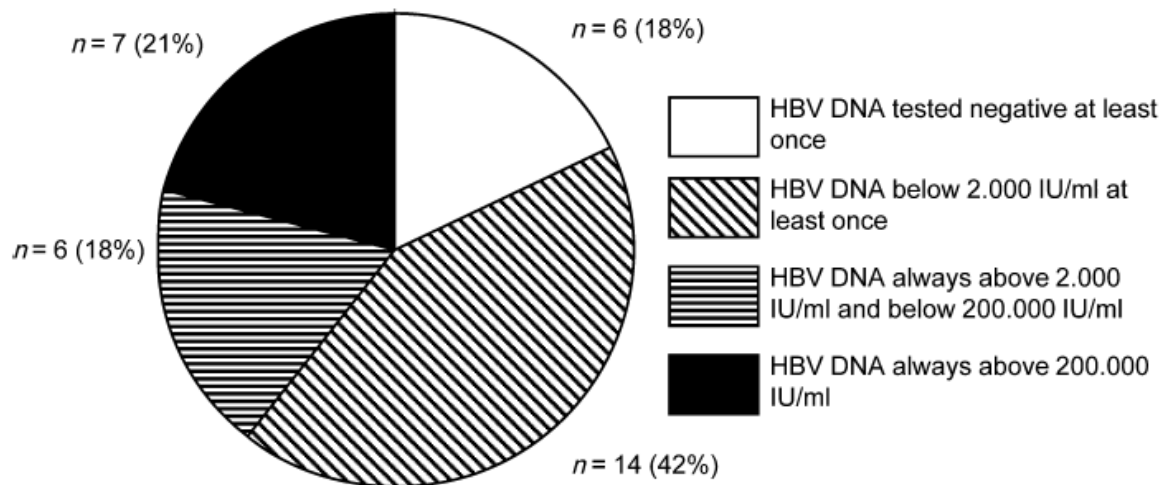

Fluctuating Patterns of Viral Dominance in Hepatitis D

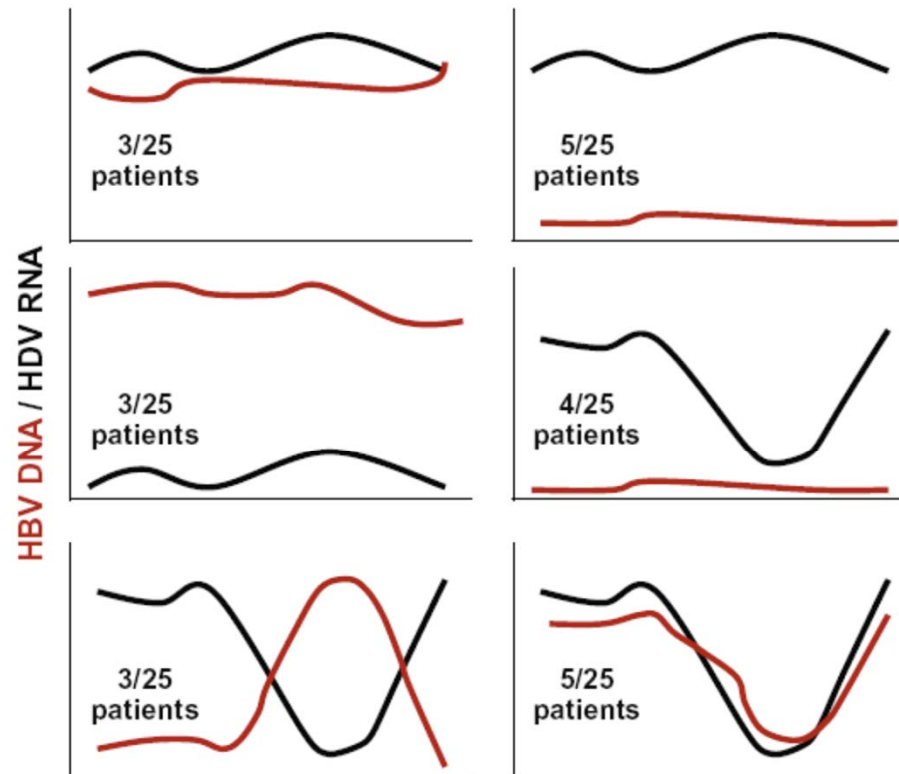
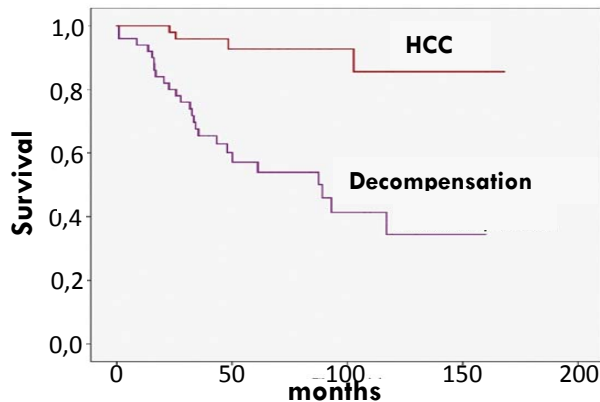

Fig. 1. Schematic representation of HBV DNA and HDV RNA patterns over time observed in the study by Schaper et al. [19].

Schaper, Buti et al., J Hepatol 2010; Wedemeyer J Hepatol 2010

Liver disease progression

- 28-year prospective study in Italy: 25% with liver cirrhosis developed HCC, 59% - liver failure
- Study in Taiwan: 15% survival within 15 yrs



- The main cause of death in patients with CHD is the decompensation of progressive liver disease (38%) instead of hepatocellular carcinoma

G Fattovich, G Giustina, E Christensen et al. *Gut* 2000;46:420-426; Farci P. EASL monothematic conference "Delta Hepatitis", Istanbul, Turkey, September 24-26, 2010, Oral; Bonino F, Negro F, Baldi M, et al. *Prog Clin Biol Res.* 1987;234:145-152; Romeo, R. et al. *Gastroenterology* 136, 1629-1638 (2009); Su, C. W. et al. *Gastroenterology* 130, 1625-1635 (2006); Calle-Serrano et al., AASLD 2009; Romeo et al., *Gastroenterology* 2009

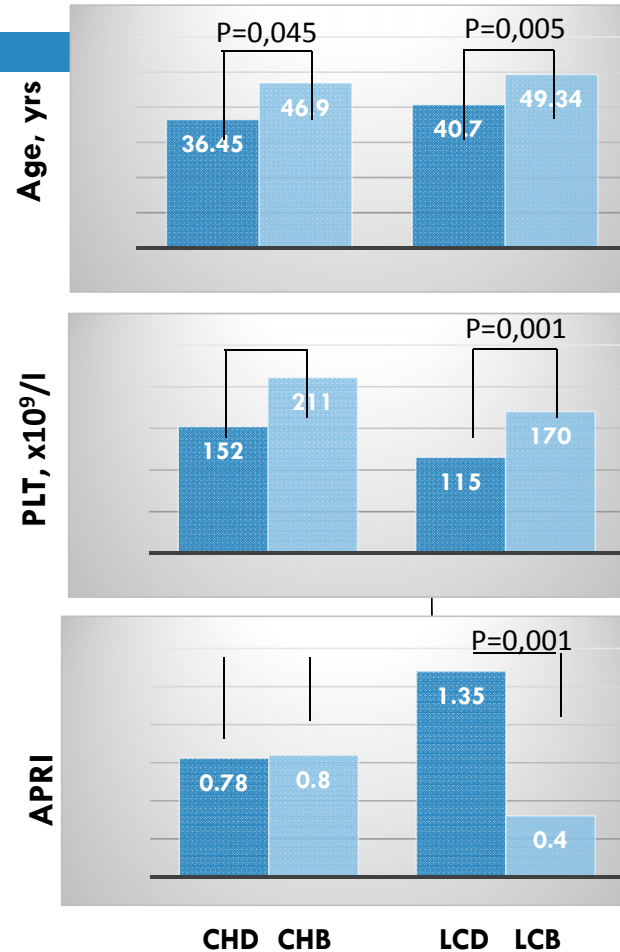

- More rapid progression of HDV compare to HBV
 - Patients with CHD are as many as 10,5 years younger than those with CHB
 - Patients with LCD are as many as 8,7 years younger than those with LCB
- More frequent complications of LCD
 - Portal hypertension
 - HE
- More frequent / severe thrombocytopenia, more higher APRI

A.V. Nersesov, E.A. Izatullayev, L.K. Palgova et al. *Clinical peculiarities of HDV infection in Kazakhstan. EASL Monothematic Conference: Delta Hepatitis, Istanbul, Turkey, Sept.r 24-26, 2010.- Abstracts.- P.133.*

Outcomes of Hep D depends on HDV genotype

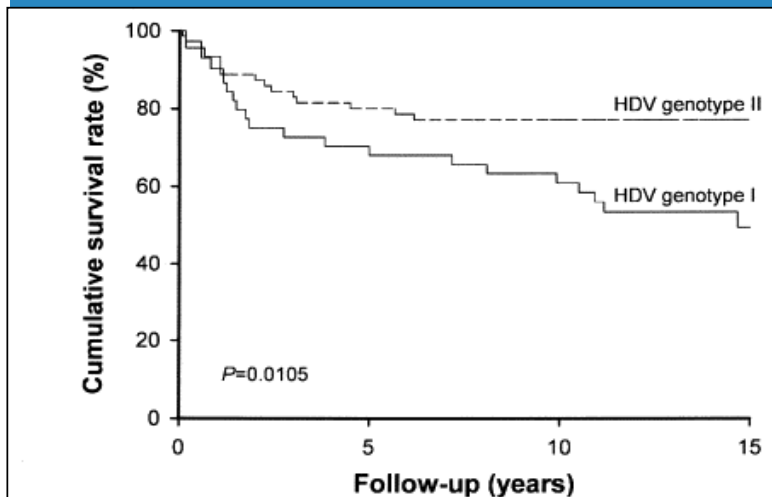

- G1 HDV in acute hepatitis
 - A risk of fulminant failure
- G1 HDV in chronic hepatitis
 - Rapid progression to cirrhosis
 - Risk of HCC is as many as 3 times higher
 - Mortality is as many as 2 times higher

Anti-HDV IgM-status correlates with activity and outcomes of Hep D

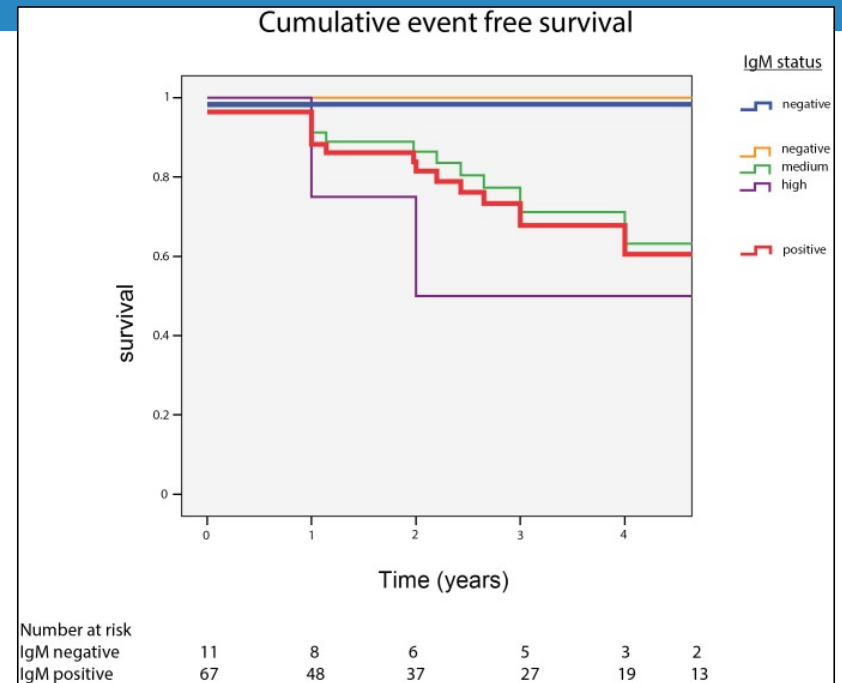

- Serum anti-HDV IgM is a robust marker to determine disease activity in Hep D which has prognostic implications

Fattovich G et al. *Gut* 2000; 46:420 2. Wu *Lancet* 1995; 3. Su et al. *Gastroenterol* 2006; 4. Wu *Curr Top Microbiol Immunol* 2006

Wranke A, Heidrich B, Ernst S et al. *PLoS One*. 2014 Jul 29;9(7):e101002. doi: 10.1371/journal.pone.0101002. eCollection 2014.

HDV RNA viral load did not correlate with activity

Outcome of CHD does not depend on HBeAg-status

Table 4. Characteristics of hepatitis delta patients (n = 73) according to the histological activity index

	HAI 0–7 (n = 38)	HAI 8–18 (n = 35)	P value
Age	39 ± 11.8	37 ± 10	NS
Male (%) / female (%)	25 (65.8) / 13 (34.2)	23 (65.7) / 12 (34.3)	NS
WBC (10 ⁹ /L)	5.9 (1.9–10.9)	5 (2.8–7.6)	0.033
PLT (10 ⁹ /L)	183.6 ± 47.9	151.4 ± 45.5	0.005
AST (U/L)	65.5 ± 54.5	92.7 ± 60	0.046
ALT (U/L)	71 (27–332)	111 (42–660)	0.002
γ-GT (U/L)	34 (14–396)	68 (19–497)	0.003
ALP (U/L)	69 (36–234)	77 (47–286)	0.011
Bilirubin (mg/dl)	0.8 ± 0.4	0.8 ± 0.44	NS
Albumin (g/dl)	4.1 ± 0.46	4.1 ± 0.5	NS
HBsAg (IU/ml)	7.4 × 10 ³ (67–4.3 × 10 ⁴)	1.4 × 10 ⁴ (668–7.9 × 10 ⁴)	0.011
HBV DNA			
	1397 (0–6.4 × 10 ⁸)	148 (0–4.4 × 10 ⁵)	0.013
	(n = 35)	(n = 32)	
HDV-RNA (copies/ml)	5.7 × 10 ⁵ (1200–1.7 × 10 ⁷)	9.7 × 10 ⁵ (1080–8.4 × 10 ⁷)	NS
	(n = 35)	(n = 32)	
HBsAg expression ≥ 2+ (%)	14 (40)	8 (24.2)	NS
	(n = 35)	(n = 33)	
HBcAg expression (%)	30 (85.7)	21 (63.6)	NS
	(n = 35)	(n = 33)	

Data are expressed as mean ± SD or median (range) as appropriate. Abbreviations are same as in Tables 1 and 2.
NS, non significant.

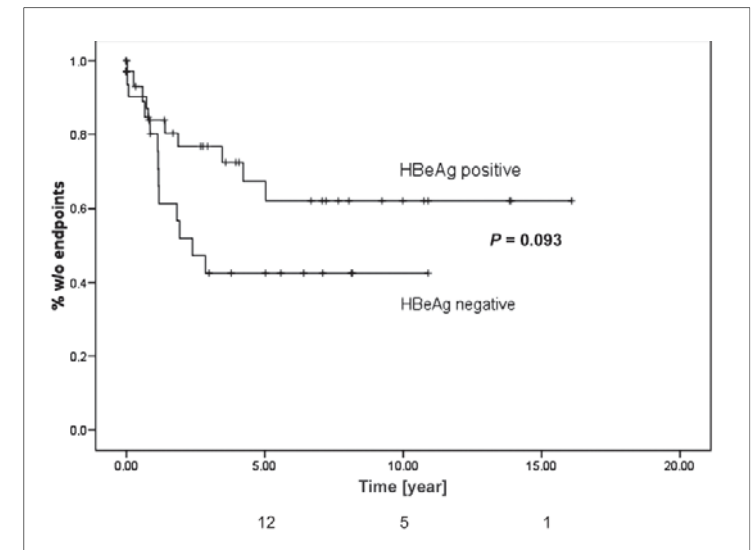

Zachou K., Yurdaydin C., Dienes H.P., Manns M.P. et al. *Liver Int.* 2010 Mar; 30(3):430-7.

Heidrich et al., *Liver International* 2012

HDIN 11 2016

- 1605 patients in the database
- Need cholinesterase for HDIN BEA fibrosis score
- Test for liver function or hepatic reserves, synthesized in hepatocytes, 11 variants, 20 individual variations, diff stage of F0-F3 from F4, correlates with CTP, MELD correlation, (Pakistan AASLD 2016)
- 63% male
- Median age 36
- 85% RNA +
- 25% HBeAg(+)
- 70% plt below 100 000 in 60%
- INR high in 70%
- 75 % received INF therapy
- 25% Nuc only

CDC 11 2016

- Aby Diasorin increasing prevalence via NHANES
- PCR: LOQ is 500 copies
- 1 step assay taqMan primers in the region of the large HDV Ag
- 75 copies LOD
- Range: 100 and 100 M of quant
- 49 samples since Oct 2014
 - 73% were male
 - Median age 39 10-70 range
 - Ethnicity: wide range
 - States: in US: PA 33 cases dominated
 - Genotypes at CDC G 1 and 5 (15 cases)

Meta-analysis: antiviral treatment for chronic Hep D

- Sources: Medline, Scopus, Cochrane Library, ISI Web of Knowledge

Group A	IFNa / absence of antiviral Tx	3 RCT; n = 137	IFNa was better for biochemical EOT [OR, 0.11 (95% CI, 0.04–0.2)] and virological EOT [OR, 0.08 (95% CI, 0.03–0.2)], but not for EOFUP VR
Group B	Low / high doses of IFNa	2 RCT; n = 60	High dose IFNa was better for biochemical EOT [OR, 0.24 (95% CI, 0.08–0.73)] and virological EOT [OR, 0.27 (95% CI, 0.1–0.74)]
Group C	IFNa ± LAM / LAM	2 RCT; n = 48	No benefits
Group D	PEG-IFNa) / other antivirals	2 RCT; n = 157	PEG-IFNa was better for virological EOT [OR, 0.419 (95% CI, 0.18–0.974)], EOFUP VR [OR, 0.404 (95% CI, 0.189–0.866)] and improvement in necroinflammatory activity [OR, 0.308 (95% CI, 0.129–0.732)]

Hep D Tx

- Endpoints
 - ▣ Eradication/suppression of HDV replication
 - ▣ Eradication (Functional cure) of HBV with HBsAg clearance /seroconversion
 - ▣ Normalization of biochemical tests and liver histology improvement
- Tx
 - ▣ PEG-IFN 48 wks (may require > 1 year due to some advantages)
 - ▣ AN therapy may be considered in patients with active HBV replication with a persistent or fluctuating HBV DNA > 2,000 IU / ml
 - ▣ VR can be evaluated after 3-6 months of therapy by measuring the level of HDV RNA
- Predictors of response
 - ▣ Non 1 genotype
 - ▣ Initial viral load < 10⁶ copies/ml
 - ▣ PCR HDV RNA (--ve) at month 6 of Tx
 - ▣ Lower Initial HBsAg titer

EASL Clinical Practice Guidelines: Management of chronic hepatitis B virus infection. Journal of Hepatology, 2012 vol. 57 p. 167–185; Hughes S. EASL monothematic conference “Delta Hepatitis”, Istanbul, Turkey, September 24-26, 2010, Abstr.138; Stern. EASL monothematic conference “Delta Hepatitis”, Istanbul, Turkey, September 24-26, 2010, Abstr.186; Castelnau et al. Hepatology, 2006.

HDV Tx

- Trials with PEG-IFN α showed HDV RNA negativity rates of 25-30% 24 weeks after therapy
- Therapy up to 5 years can result in 35% long-term SVR
- Retrospective-prospective follow-up of 77 patients in the HIDIT-1 trial with a median time of follow-up of 4.5 (0.5-5.5) years
 - Out of 16 patients tested HDV RNA-negative 6 months after PEG-IFN α treatment, 9 individuals tested HDV RNA-positive in the long-term follow-up study

[Heidrich B¹](#), [Yurdaydin C](#), [Kabaçam G](#) et al. *Hepatology*. 2014 Jul;60(1):87-97. doi: 10.1002/hep.27102, Yurdaydin in press 2016

■ Kazakhstan

- 11 cases were analyzed
- Tx
 - Peg-IFN α 2 α , 180 μ g/wk
 - 48 wks (in 1 case – 36 wks)
- Efficacy
 - EOT VR – in 4 out of 11 pts (36,4%)
 - VR at 6 months follow up – in 3 pts (27,3%)
 - VR after 6 months follow up – in 2 pts (18,0%)

A. Nersesov, Zh. Kaibullayeva, A.Raissova, A.E.Dzhumabaeva, et al. *The Liver Week 2014, Jeju, Korea, Abstract book, P. 176.*

Late HDV RNA relapses may occur after PEG-IFN α therapy of hepatitis delta and thus the term sustained virological response should be avoided in HDV infection

The Hep-Net-International Delta-Hepatitis Intervention Trial 2: HIDIT-2

Endpoints		Peg-IFN α 2 α + TDF	Peg-IFN α 2 α + Placebo	P
Not detected HDV RNA	At the end of 96 weeks of treatment	47%	33%	NS
	Of those who completed treatment	54%	41%	NS
24-week post-treatment sustained response		30%	23%	NS
Relapse		44%	40%	NS
↓HBsAg >0.5 log IU/mL	At week 96	30%	25%	NS
	At week120	22%	25%	NS

- Lower HDV RNA and lower HBsAg levels at baseline were associated with HDV sustained virological response
- People with cirrhosis had a higher HDV virological response rate compared with non-cirrhotics (51% vs 25%, respectively)
- Prolonged pegylated interferon plus tenofovir was difficult to tolerate and did not have any benefit
- All participants had at least 1 adverse event, and one-third had serious adverse events

New treatments ?

- The drug, Ezetimibe, which is currently known to lower cholesterol, is being used in a trial in Pakistan for patients with chronic HDV (phase II):

<https://clinicaltrials.gov/ct2/show/NCT03099278?term=hepatitis+D&rank=4>

LT in HDV-infection

- The only available option for pts with FHF, end-stage liver disease and HDV-associated HCC who are not candidates for resection
- LT for HDV: The best outcomes amongst all other viral hepatitis (including HBV monoinfection)
 - Compared to HBV monoinfection, in HDV infection the HBV graft infection risk is lower
 - With the prophylactic HBIg and NAs, the incidence of HBV/HDV graft infection is 0-5%
 - After LT the long term prophylaxis of HBV graft infection is recommended
 - There is no any effective treatment of graft HDV infection

ten Kate FJ, Schalm SW, Willemse PJ et al. J Hepatol 14:2-3 1992 Mar: 168-75; Samuel D, Muller R, Alexander G et al. N Engl J Med 1993; 329:1842-7; Smedile A, Casey JL, Cote PJ et al. Hepatology 1998;27:1723-9; Rifai K, Wedemeyer H, Rosenau J et al. Clin Transplant. 2007; 21(2): 258\$ [Roche B](#), [Samuel D. Seminars in liver disease](#) 32:3 2012 Aug pg 245-55; Wedemeyer H. Hepatology. Clinical textbook. Flying publisher, 2012. 546 p..

Efficacy of prolonged tenofovir therapy on hepatitis delta in HIV-infected patients

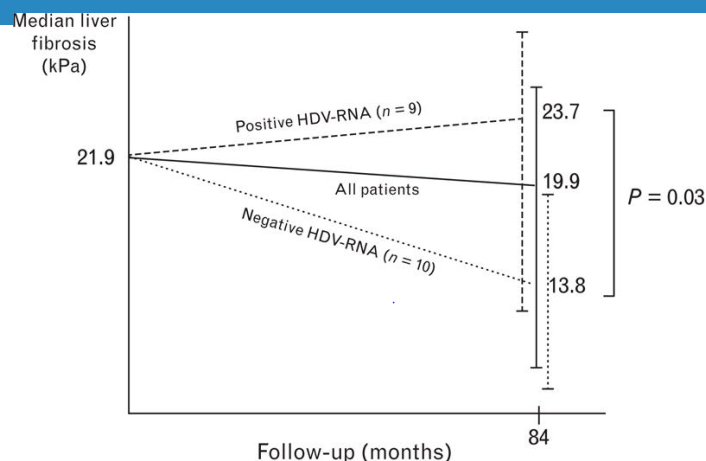
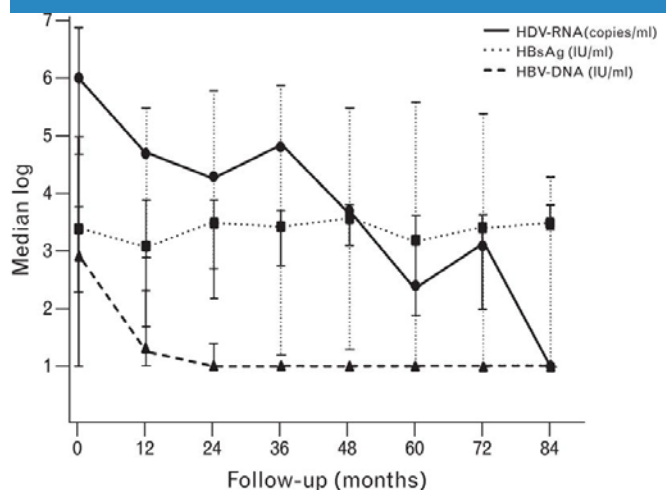

After a median tenofovir exposure of 58 (34–93) months, all patients had undetectable HBV-DNA and 10 (53%) HDV-RNA less than 10 copies/ml. In the last group, the median time to reach undetectable HDV-RNA was 54 (33–72) months. In the remaining nine HDV viremic patients at the end of follow-up, the median HDV-RNA had dropped to 2.42 (1.27–3.09) log copies/ml

During tenofovir therapy, there was an overall reduction in liver stiffness from a median of 21.9 to 13.8 KPa ($P = 0.34$). More than 30% reduction in liver stiffness during the study period occurred in six out of 10 (60%) patients who achieved undetectable HDV-RNA. Regression of cirrhosis was recognized in five patients, all of whom had achieved undetectable HDV-RNA.

Conclusion: Long-term exposure to tenofovir significantly reduced serum HDV-RNA apart from completely suppressing HBV-DNA in HIV-infected patients with hepatitis delta. This virological benefit is accompanied by significant improvements in liver fibrosis.

HDV Assays in the US

- ARUP has launched a qHDV RNA test that is available at no cost to registered participants
- Launch of commercial assay to the general medical community occurred simultaneously

HDV Awareness and Testing Program Roles



Program sponsor



*Patient / HCP
education*



*Centralized HDV
testing*



Providers



Test HBV patients

Hepatitis Delta Testing

ARUP Laboratories

Hepatitis Delta Total Antibody (IgM and IgG)*

- *Qualitative enzyme immunoassay*
- *Detects but does not differentiate IgM and IgG*
- *Results reported as 'negative', 'positive', or equivocal*
- *Performance characteristics are similar to other commercially available HDV antibody tests*

HDV Viral Load by PCR*

- *Real time RT-PCR that quantifies HDV RNA*
- *Internal control monitors nucleic acid extraction and detects PCR inhibitors*
- *Calibrated to WHO standard*
- *Dynamic quantitative range of 120 - 5,800,000 IU/mL*
- *Lower limit of detection = 62 IU/mL*

*This test was developed and its performance characteristics determined by ARUP Laboratories. The U. S. Food and Drug Administration has not approved or cleared this test.

Perspectives of the Hep D therapy

- Other IFNs
 - ▣ IFN λ
 - ▣ (Albuferon)
- Combination therapy
 - ▣ IFN with NA, other agents
- Specific agents
 - ▣ Myrcludex B (inhibitor of HBV and HDV penetration)*
 - ▣ Prenylation inhibitors
- Improvement of LT medical support
- Lonafarnib trial
 - Oral prenylation inhibitor
 - 14 patients were enrolled, of whom eight were assigned to group 1 and six were assigned to group 2 (placebo control)
 - lonafarnib effectiveness in blocking HDV production was greater in group 2 than in group 1 (0.952 [SE 0.06] vs 0.739 [0.05], $p < 0.001$), and the HDV half-life was 1.62 days (0.07)
 - There was no evidence of virological resistance
 - Adverse events were mainly mild to moderate; no treatment discontinuations occurred in any treatment groups

Conclusions

- HDV-infection plays an important role in the etiology of liver diseases in various parts of the world
- All HBsAg-positive patients should be tested for anti-HDV using serology and confirmation with HDV RNA by quant PCR
- Clinical outcomes of HDV-infection depend on time interval of HBV- and HDV-infections (co- or superinfection), viral and host factors
- Outcome of CHD superinfection is characterized by rapid progression to cirrhosis, end stage liver disease and HCC
- There is currently no approved therapy for HDV. Peg-IFN α has been used to treat HDV with modest antiviral activity of 15-25% SVR after 1 year of treatment.
 - ▣ Although emerging data in Turkey may show up to a 35-40% MVR rate with treatment up to 5 years
- Prevention HDV = vaccination against HBV
- LT with CHD is characterized by better outcomes compare to other VH (including HBV mono-infection)
- SVR after 48-week PEG IFN α Tx is <25 %
- Most often HDV dominates over HBV, but in HBV DNA-positive cases can be used HBV-polymerase inhibitors
- Combination of PEG IFN α and NAs does not improve Tx results
- Late HDV RNA relapses may occur after PEG-IFN α therapy of hepatitis delta and thus the term sustained virological response (new term MVR Maintained Virologic Response) should be avoided in HDV infection
- Treatment up to 5 years would be consider optimal with on treatment monitoring of HDV RNA q until we have new oral/injectable therapies that can clear HBsAg or HDV RNA cure

Q & A

Please submit questions for Dr. Gish in the chat box!



Thank You! Please complete the post-webinar survey!

Connect with us!

Hepatitis Delta Connect Website:

www.hepdconnect.org

Twitter, Facebook, Instagram

[@hepdconnect](#)



Still have Questions?

Email us at connect@hepdconnect.org